

# CONTROLLER MODELLING AND DESIGN OF ROTATIONAL SPEED FOR INTERNAL COMBUSTION ENGINE

**Dr. Raof M. Radhi**

Lecher, shawajin @yahoo.com

**Dr. Emad Q. Hussien**

Lecher, emadslamy@yahoo.com

## ABSTRACT

This paper proposes a controller design of a nonlinear model of an internal combustion engine based on linear quadratic regulator (LQR) technique. The design takes into consideration the effect of external disturbances that occurs during the operation of system. The equations of motion are linearized according to the perturbation theory in order to inspect the dynamic stability of the engine motion, and the subsequent design of appropriate feedback controllers for the system, which can be obtained by solving the LQR problem. The results show that the proposed controller has good performance and stability than PID controller. The simulations have been carried out in Matlab/Simulink environment.

## الخلاصة

يهدف البحث الى تصميم سيطرة على النموذج اللاخطي لمنظومة محرك الاحتراق الداخلي على أساس تقنية LQR. يأخذ التصميم بنظر الاعتبار الاضطرابات الخارجية المؤثرة على عمل المحرك ، ويمر على تحول المعادلات الحركة الى النموذج الخطي حسب نظرية الاضطراب ومن ثم دراسة الاستقرار الديناميكي لاداء المحرك وبالتالي تصميم منظومة مناسبة لوحدة تحكم ردود الفعل من خلال معالجة معوقات تطبيق LQR. أظهرت النتائج البحث ان وحدة التحكم المقترحة قد ادت الى تحسن واضح في اداء والاستقرارية للمنظومة بالمقارنة مع المسيطر PID ، علما ان عملية المحاكاة قد تمت في اطار SIMULINK / MATLAB.

**Keywords:** - internal combustion engine, nonlinear model, feedback linearization, LQR

## Methodology

## 1-INTRODUCTION

There are many kinds of systems in common industrial, transportation, and domestic use that need to be controlled in some manner, and there are many ways in which that can be done. In all types of heat engine, the expansion of the high-temperature and high pressure gases produced by combustion applies direct force to some component of the engine, such as pistons, turbine blades, or a nozzle. This force moves the component over a distance, generating useful mechanical energy [1].

An automotive engine is a typical multiple-input multiple output system that has to satisfy a number of performance criteria under different operating conditions. Controller development for an internal combustion engine is a challenging engineering problem that requires background of different disciplines such as thermal engineering, dynamics, and control theory [2].

Most engine systems have idle speed control built into the electronic control unit (ECU). The engine rotation (rpm) is monitored by the crankshaft position sensor which plays a primary role in the engine timing function for fuel injection, spark events, and valve timing. The idle speed control (ISC) system regulates engine, by adjusting the volume of air that is allowed to bypass the closed throttle valve.

The main source of performance deterioration of the speed control system is disturbances such as rapid external load changes and slow varying changes in operating conditions. External load changes are the result of loading due to changes in operation requirements, such as an attempt for sudden stop which subject the engine to a very high deceleration level, or may be fast acceleration for sudden high speed demand, as well as city driving during busy traffic. All of these operating conditions lead to variable power demand and thereby engine speed fluctuation. However, the engine may be equipped with means to satisfy such requirements, but sacrifices have to be accepted

Power demand variation and so, engine speed fluctuation causes instantaneous air/fuel mixture changes between lean and rich values, which both have adverse effects on engine [3], i.e:

1. Rich mixture burns faster causing maximum pressure concentration near top dead center (TDC) and so, resulting in rough operation, as well as reduces time for heat transfer to occur from cylinder, thus raising overall gas temperature which increases NO<sub>x</sub> formation rate.
2. Lean mixture slows flame speed and thus combustion lasts well past TDC. This keeps the high pressure well into power stroke, again raising gas temperature. High temperature together with unused oxygen of lean mixture oxidizes exhaust valves and seats, as well as increasing NO<sub>x</sub> formation rate.

During transient period, the engine speed settling time may be significant, giving thereby a fair instant of time for the rotational speed to bounce between acceleration/deceleration modes. This will cause, as mentioned above, severe deterioration in both engine power and

operation economy. The scope of this work is therefore set to overcome all of these disturbances problems.

Many different closed loop designs have been proposed in the literature including  $H_\infty$  control [4],  $H_2$  control [5], sliding mode control [6],  $\ell_1$  optimization [7], feedback linearization [8], proportional-integral-derivative (PID) control [9], linear quadratic control (LQ) [10], and adaptive control [11,12]. A comparison between different control algorithms methods can be found in [13].

The objective of this paper is to maintain engine speed at a prescribed set-point in the presence of random disturbances. It's proposed LQR technique as a method for controlling the engine rotational speeds.

## 2-SYSTEM DESCRIPTION

The engine model contains inlet and exhaust manifolds, torque generation, internal friction and crank shaft dynamic. This creates a torque and a rotational motion on the crankshaft which depend on load, pressure in the cylinder, mass of all parts in motion and the geometry of the engine as shown in Fig.(1)[14].

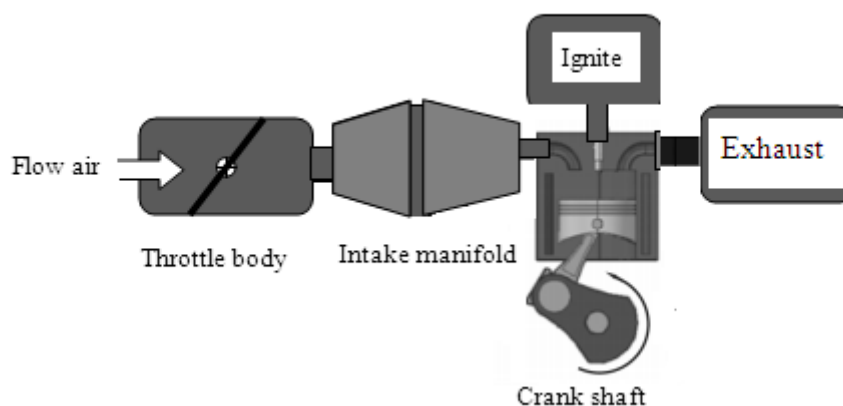

Fig. (1) Schematic of engine speed system

## 3- DYNAMIC OF ENGINE NON- LINEAR MODEL

The nonlinear model is based on the work of Powell and Cook [15]. It's block diagram is shown in Fig.(2). The engine speed can be controlled by the throttle angle and ignition timing. The manipulated variable (input) is computed by the error between the engine speed, which can be measured by a crank sensor, and the desired one. An application of conventional PID control is invalid to such nonlinear engine control system with variation of the desired speed and system parameters.

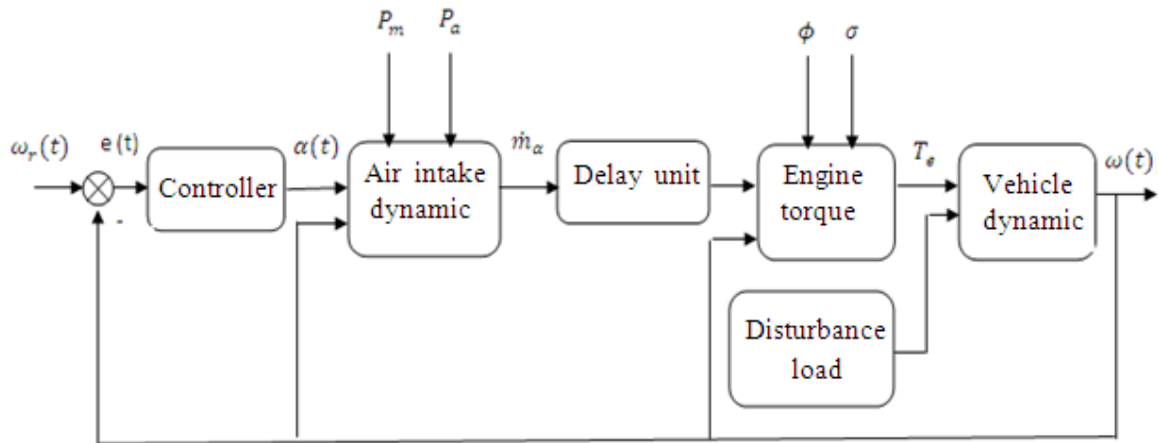

Fig.(2) Non-linear engine model

The differential equations describing the overall engine dynamics are given by [14, 16]:

$$\left. \begin{aligned}
 \dot{m}_\alpha(t) &= C_d(P_m)A_{th}(\alpha) \frac{P_a}{\sqrt{RT_a}} \psi\left(\frac{P_a}{P_m}\right) \\
 \dot{m}_\beta(t) &= \frac{P_m}{RT_m} \xi_{vol}(P_m, \omega) V_d \frac{\omega}{2\pi} \\
 \dot{P}_m(t) &= \frac{RT_m}{V_m} (\dot{m}_\alpha - \dot{m}_\beta) \\
 T_e(t) &= \xi_{ind} H_0 \frac{Z}{4} \pi \dot{m}_\beta \\
 \dot{\omega}(t) &= \frac{1}{J_e} (T_e - T_d)
 \end{aligned} \right\} \quad (1)$$

Where,  $C_d(P_m)$  is the discharge coefficient, this coefficient compensates for flow losses and variations of the effective throttle area  $A_{th}(\alpha)$ , and  $\psi\left(\frac{P_a}{P_m}\right)$  is the pressure ratio. Can be expressed the rate of change of manifold pressure  $\dot{P}_m(t)$  as a nonlinear function of  $\alpha(t), P_m(t)$  and  $\omega(t)$  as follows [14, 17]:

$$\begin{aligned}
 \dot{P}_m(t) &= \\
 f_1(P_m(t), \omega(t), \alpha(t)) & \quad (2)
 \end{aligned}$$

The load torque on the engine is not known a priori. It is due to aerodynamic resistance, road, and the internal engine friction. In general, the generated torque ( $T_e$ ) is a nonlinear function of engine speed, mass flow rate into the engine cylinders, equivalence ratio ( $\phi$ ) and spark advance ( $\sigma$ ). The time delay ( $\tau$ ) in the engine model equals approximately 180 degrees of crank angle advance, and Thus is a speed dependent parameter. Additionally, most engine control activities are event driven and synchronized with position .Therefore, the rate of change of engine speeds can be expressed in the following form:

$$\dot{\omega}(t) = f_2(P_m(t), \omega(t), T_d(t)) \quad (3)$$

#### 4- FEEDBACK LINEARIZATION

The basic idea with feedback linearization is to transform the nonlinear systems dynamics into a linear system. Conventional control techniques like pole placement and linear quadratic optimal control theory can then be applied to the linear system. Feedback linearization allows us to design the controller directly based on a nonlinear dynamic model that better describes a shape maneuvering behavior.

The equations of motion are linearized according to the perturbation theory in order to inspect the dynamic stability of the engine motion [18] .The linearized state-space representation around an operating point is developed from the dynamic equations:

$$\dot{x} = Ax + Bu + B_d d \quad (4)$$

$$y = Cx + uD \quad (5)$$

State vector are defined by  $x^T = [P_m \quad \omega]$  ,  $u = [\alpha]$  and state matrices A, C and D are given by;

$$A = \begin{bmatrix} \frac{\partial f_1}{\partial P_m} & \frac{\partial f_1}{\partial \omega} \\ \frac{\partial f_2}{\partial P_m} & \frac{\partial f_2}{\partial \omega} \end{bmatrix}, \quad C = [0 \quad 1], \quad D = [0]$$

Setting

$$B = \begin{bmatrix} \frac{\partial f_1}{\partial \alpha} \\ \frac{\partial f_2}{\partial \alpha} \end{bmatrix}, \quad B_d = \begin{bmatrix} \frac{\partial f_1}{\partial T_d} \\ \frac{\partial f_2}{\partial T_d} \end{bmatrix}$$

In this case, this model is used to design a controller for the system.

### 5-LQR DESIGN

Linear Quadratic Regulator (LQR) is a widely used control technique. It is preferred because of its easy implementation and its optimality for linear time invariant systems. It is an optimal and robust technique for Multi-Input Multi-Output (MIMO) control using this method [10, 8].

From Eqns.(4) and (5) above ,the derivation which is given a linear time invariant system in state variable with disturbance. For LQR control the following cost function is defined

$$J = \frac{1}{2} \int_{t_0}^{t_1} (X' Q x + u' R u) dt \tag{6}$$

The object of LQR control is to find a state feedback gain matrix,  $K$  such that the cost function is minimized. The matrices  $Q$  and  $R$  are weighting matrices, which determine the closed loop response of the system. The solution to this problem starts with finding a control law in the form of the following;

$$u = -R^{-1}B'P(t)x(t) - R^{-1}B'\xi(t) \tag{7}$$

Where,  $P$  and  $\xi$  are obtained from the following equations

$$\dot{P} + PA + A'P - PBR^{-1}BP + C'QC = 0 \tag{8}$$

$$\dot{\xi} + (A' - PBR^{-1}B')\xi - PB_d d = 0 \tag{9}$$

If  $t_1 \cong \infty$ ,  $P$  and  $\xi$  are steady state solutions;

$$A'P + PA - PBR^{-1}BP + C'QC = 0 \tag{10}$$

$$\xi = -(A' - PBR^{-1}B')\xi - PB_d d \quad (11)$$

In other words, the control law contains both feedback states and feed forward disturbance

$$u = -Kx(t) + K_d d \quad (12)$$

With;

$$K = R^{-1}B'P$$

$$K_d = R^{-1}B'(A' - PBR^{-1}B')PB_d$$

## 6-SIMULATION RESULTS

A linear engine model was established in Matlab/Simulink to evaluate the performance of LQR controller. The numerical simulations have been performed using engine having characteristics shown in **Table 1**, and are taken from reference [19].

**Table 1. Technical specification of the engine**

Parameter	Value
$P_a$	$1.013 \cdot 10^5$ Pa
$V_m$	$6.8 \cdot 10^{-3}$ $mm^3$
$V_d$	3.77 $mm^3$
$T_m$	350 k
R	281 J/kg.k
$T_a$	296 k
Z	4
$H_0$	$45.6 \cdot 10^6$ J/kg
$J_e$	0.15 $kg \cdot m^2$
$T_d$	2 N.m

The space matrices  $A, B, C$  and  $D$  are obtained after substituting the operating point state values, as shown in Fig.(3). The state weight matrix,  $Q$  and the control weighting matrix,  $R$  are chosen by Bryson's rule. These choices are used as just the starting point for a trial and error iterative design procedure aimed for the desirable properties in the close-loop system.

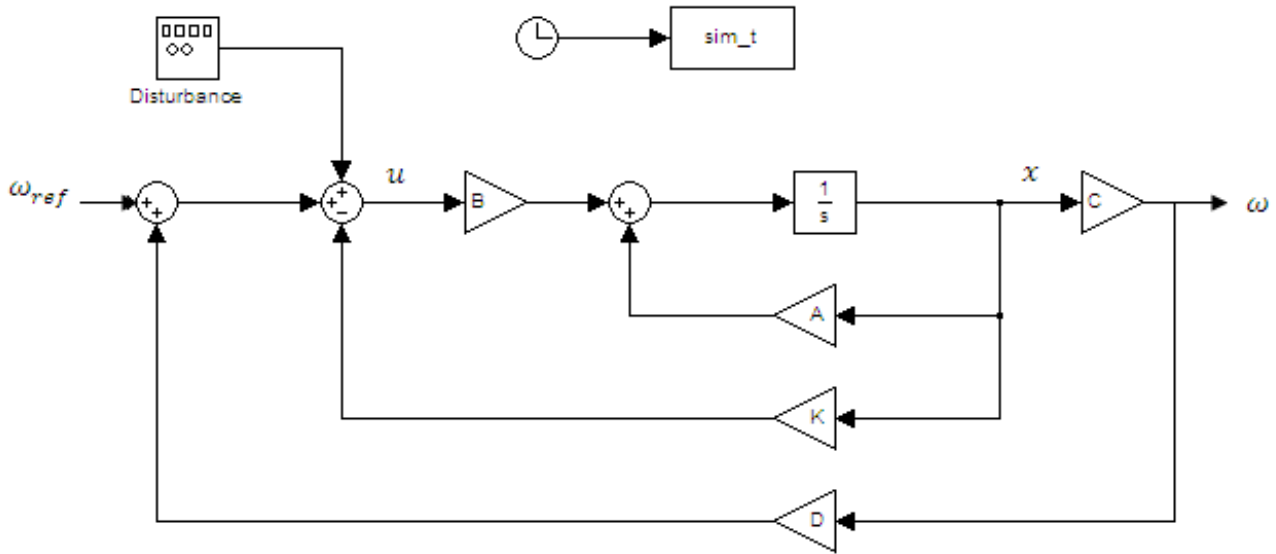

Fig.(3) Schematic representation of state space control using a LQR controller

The PID controller is used for controlling the engine speed. The PID controller parameter are tuned to give the optimal performance;  $K_p = 0.0001$ ,  $K_i = 0.01$ , and  $K_d = 0.0001$ . Such controller is illustrated in Fig.(4), where  $\Delta\omega$  represents the input engine speed (error signal) and  $\Delta\alpha_c$  represents the output throttle angle change.

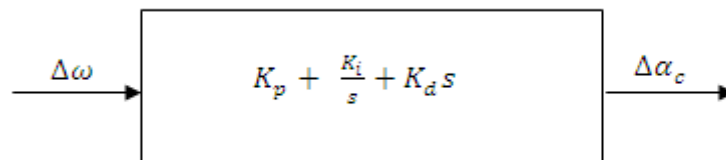

Fig.(4) PID controller

Assuming the measurable output is rotational speed of the engine and the control input is the angle of the throttle plate. The linear model was given a step change in throttle angle from  $5.5^\circ$  deg. to  $6.5^\circ$  deg. at 15 seconds, as shown in Fig.(5). The load disturbance of the engine speed is taken randomly at any time, as sinusoidal in cross- section with amplitude of  $2 N.m$ , as shown in Fig.(6).

The effect of load disturbance (torque) on the rotational speed of the engine at the time of operation  $t = (5 - 10) sec$  and  $t = (25 - 30)sec$  is shown in Fig.(7), for the open-loop system is first tested on the simulator before applying the proposed controllers.

The simulation results of the engine speed shown in Figs.(8) and (9), to verify the effectiveness of the LQR controller comparing to both the open-loop system and PID



controller. The effectiveness of each controller is test and verified using Matlab/Simulink environment. The PID controller has percentage of overshoot and consequent the takes some time to its stabilizing the system .It also has the time settling that can reach more than 5 sec, this will affect the effectiveness of the system.

Therefore, it's concluded that the LQR controller give the best performance in terms of lower amplitude and faster settling time compared to PID controller.

## 7-CONCLUSIONS

Rotational speed control of an internal combustion engine is an important issue, so this paper presents a design method for engine speed control using LQR method. The objective of the research was to evaluate the exiting methods for estimating the engine speed variations. An application of LQR law to such nonlinear engine control system is valid for the variation of the desired speed and system parameters. The obtained results showed that the presented controller has shorter settling time and smaller overshoot compared to the both PID controller and open-loop system.

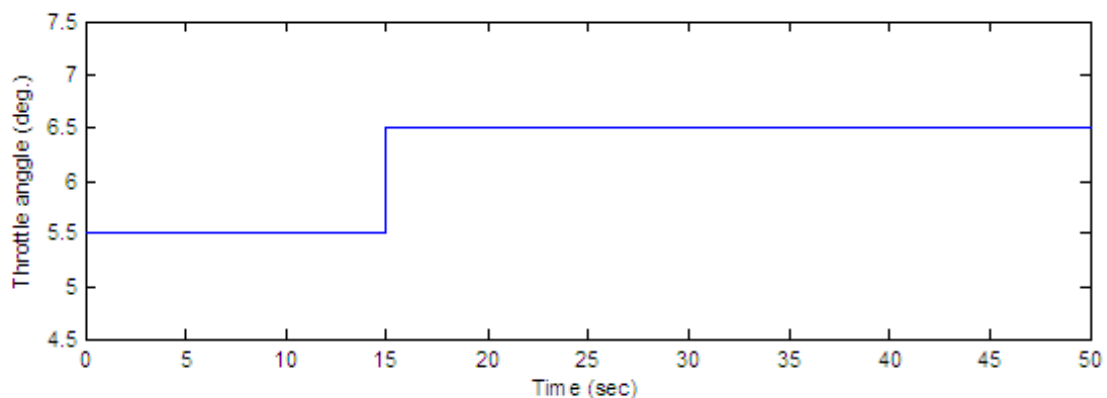

**Fig.(5) Variation of air throttle angle with time of operation system**

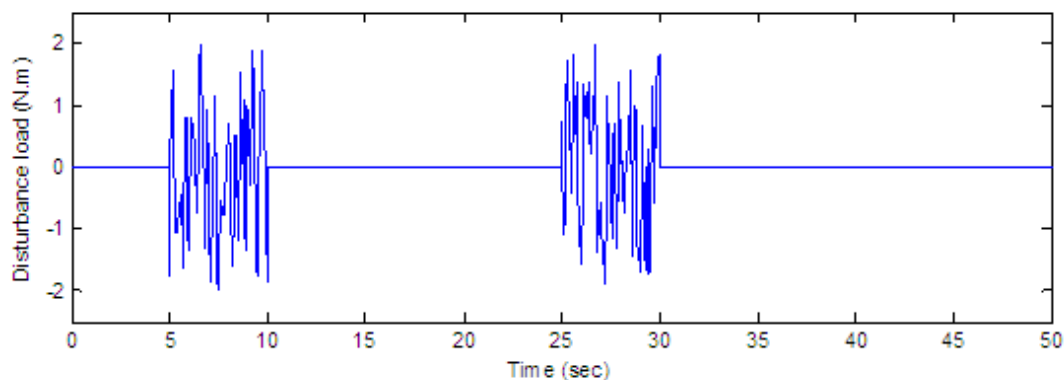

**Fig.(6) Random disturbance load variation with time of operation system**

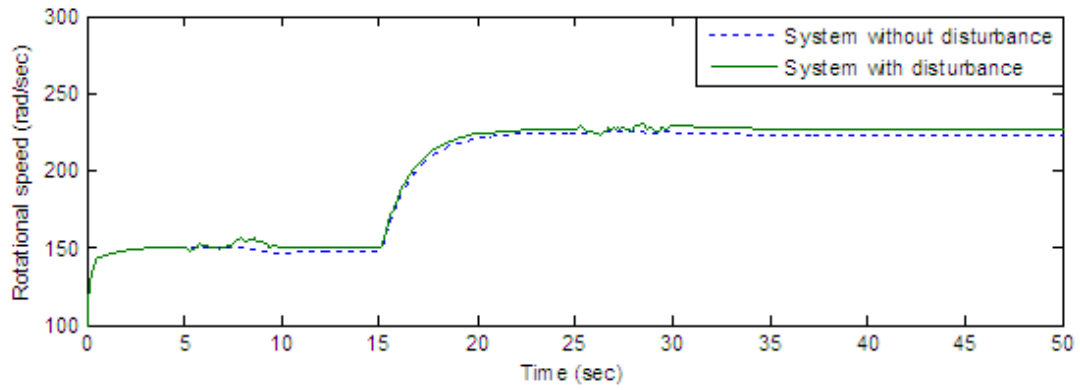

**Fig.(7) Variation of engine speed with time of operation for open loop system**

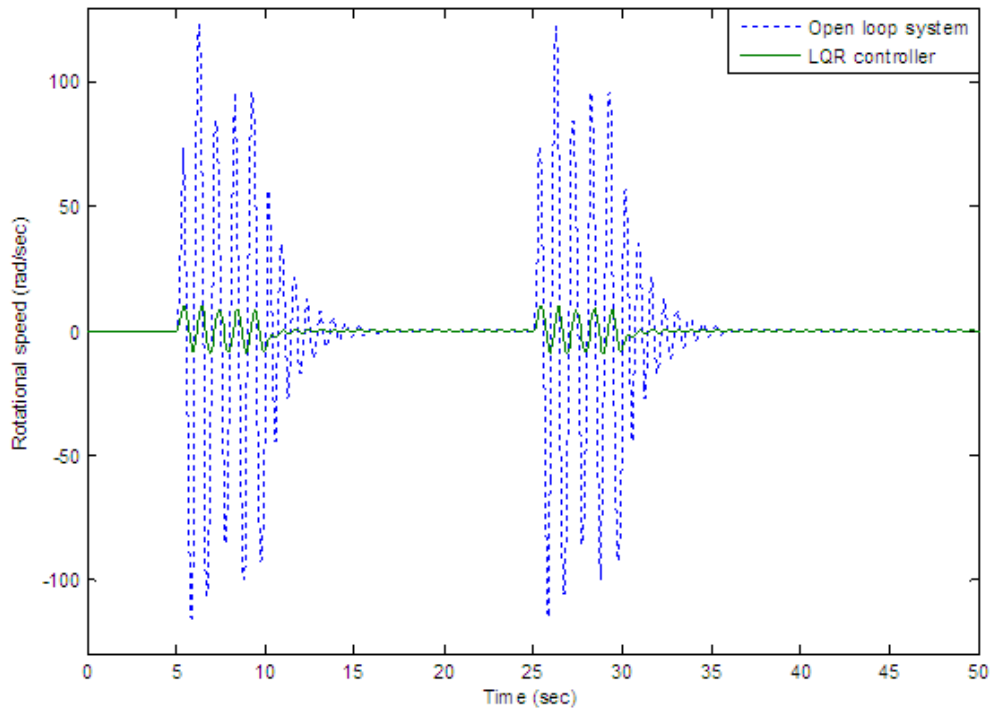

**Fig.(8) Time response of engine speed for closed loop system at different system**

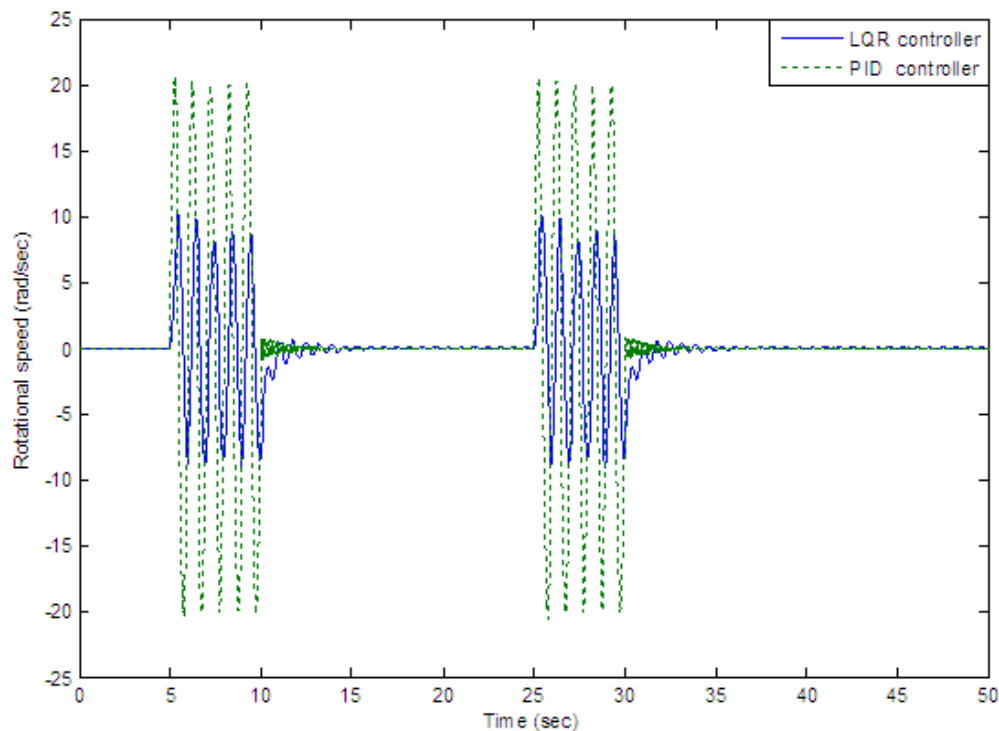

**Fig.(9) Time response of engine speed for closed loop system at different method**

## REFERNCES

- [1] Chen B.C. , Hsieh F.C., 2005 ,“ Estimation of Engine Rotational Dynamics Using a Closed-loop Estimator with Stroke Identification for Engine Management Systems”, Journal of Automobile Engineering.
- [2] Bengtsson F., 2006, “Estimation of Indicated– and Load Torque from Engine Speed Variations”, Dept. of Electrical Engineering at Linkoping University.
- [3] Push Karaj A. P., 2005, “Dynamic Modeling and Control of Port Fuel Injection Engines”, Master of Technology in Mechanical Engineering, Indian Institute of Technology Bombay.
- [4] Williams S. J., 1989, “Idle Speed Control Design Using an  $H_{\infty}$  Approach”, in Proc. Amer. Control Conf., pp. 1950–1956.
- [5] Filippi R. D., Scattolini R., 2005, “Idle Speed Control of a F1 Racing Engine”, Control Eng. Practice, vol. 14, no. 3, pp.251–257.

- [6] L. Kjergaard S. N., Vesterholm T., Hendricks E., 1994, "Advanced Nonlinear Engine Idle Speed Control Systems", in Proc. of SAE, no. 940974.
- [7] Butts K. R. N., Sun J., 1999, "Application of  $\ell_1$  Optimal Control to the Engine Idle Speed Control Problem", IEEE Transactions on Control Systems Technology, vol. 7, no. 2, pp. 258–270.
- [8] Chien T. L., Chen C. C., Hsu C.Y. 2005, "Tracking Control of Nonlinear Automobile Idle-Speed Time-Delay System via Differential Geometry Approach", Journal of the Franklin Institute, vol. 342, no. 7, pp. 760–775.
- [9] Kokotovic P. K., Rhode D., 1986, "Sensitivity Guided Design of an Idle Speed Controller", Ford Motor Company, PK Research, Urbana, U.S.A., Technical Report 1.
- [10] Agudelo J. R., 2011, "LQR Control for Speed and Torque of Internal Combustion Engines", Milano Italy.
- [11] Kim D., Park J., 2007, "Application of Adaptive Control to the Fluctuation of Engine Speed at Idle", Information Sciences, vol.177, no. 16, pp. 3341–3355.
- [12] Hsieh F. C. Chen B.C., Wu Y.Y., 2007, "Adaptive Ideal Speed Control for Spark Ignition Engines", National Taipei University of Technology.
- [13] M. T. S., Sindano H., 2000, "A Comparison of Idle Speed Control Schemes", Control Eng. Practice, vol. 8, no. 5, pp. 519–530.
- [14] WEI T. C., 2009, "Modeling and Control and Control of an Engine Fuel Injection System", Master of Engineering University Teknologi Malaysia NOVEMBER.
- [15] Powell B.K., Cook J.A., 1987, "Nonlinear Low Frequency Phenomenological Engine Modeling and Analysis", proceedings of the American Control Conference, Volume 1, PP.332-340.
- [16] VAN N.H., 1994, "Stability Analysis of a Single Point Injection Engine at Idle", Master's Thesis Eindhoven University of Technol, August.
- [17] Nikzadfar K., Shamekhi A.H., 2011," Developing a State Space Model for a Turbocharged Diesel Engine Using Least Square Method", Khaje Nasir University of Technology SAE International.
- [18] Guzzella1 R.P., 1999,"Feedback Linearization Idle Speed Control Design and Experiments", Vol. 35, No. 4.
- [19] Guzzella L.,Onde C.R.,2004,"Introduction to Modeling and Control of Internal Combustion Engine Systems", Springer Verlag, Berlin.

**LIST OF SYMBOLS**

- $d$  Disturbance input, N. m  
 $H_0$  Calorific value of fuel, J/Kg  
 $J_e$  Mass moment of inertia for crankshaft, Kg m<sup>2</sup>  
 $\dot{m}_\alpha$  Air mass flow rate, Kg/s  
 $\dot{m}_\beta$  Mass flow rate of air inducted into cylinder, Kg/s  
 $P_a$  Atmospheric pressure, N/m<sup>2</sup>  
 $P_m$  Intake manifold pressure, N/m<sup>2</sup>  
 $R$  Universal gas constant  
 $t$  Time, sec  
 $T_a$  Air temperature, K  
 $T_d$  Disturbance torque, (N.m)  
 $T_m$  Intake manifold temperature, K  
 $u$  Control unit torque, N.m  
 $V_c$  Clearance volume, m<sup>3</sup>  
 $V_d$  Volume of cylinder, m<sup>3</sup>  
 $V_m$  Intake manifold volume, m<sup>3</sup>  
 $Z$  Number of cylinders  
 $\alpha$  Throttle angle, deg.  
 $\xi_{vol}$  Volumetric efficiency  
 $\xi_{ind}$  Indicated efficiency  
 $\omega$  Rotational speed, rad/s  
 $\omega_{ref}$  Reference rotational speed, rad/s